



Owner's Guide & Installation Instructions

Ultrasonic: Smart™ Sensor **WeatherStation® Instrument**



Patent: <https://www.airmar.com/patent.html>

Record the serial number located on the WeatherStation® Instrument.

Serial No. _____ Date of Purchase _____



California Proposition 65 Warning:

Warning: Cancer and Reproductive Harm - www.p65warnings.ca.gov

Copyright © 2026 Airmar Technology Corp. All rights reserved.

All Rights Reserved. Except as expressly provided herein, no part of this guide may be reproduced, copied, transmitted, disseminated, downloaded, or stored in any storage medium, for any purpose without prior written consent of Airmar. Airmar hereby grants permission to download a single copy of this guide and of any revision of this guide onto a hard drive or other electronic storage medium to be viewed and to print one copy of this guide or any revision hereto, provided that such electronic or printed copy of this guide or revision must contain the complete text of this copyright notice and provided further that any unauthorized commercial distribution of this guide or any revision hereto is strictly prohibited.

Information in this guide is subject to change without notice. Airmar reserves the right to change or improve its products and to make changes in the content without obligation to notify any person or organization of such changes. Visit the Airmar website at www.airmar.com for current updates and supplemental information concerning the use and operation of this and other Airmar products.

Table of Contents

Owner's Guide & Installation Instructions	1
Introduction	4
Features	4
Model Description	5
Product and Configuration Specifications	5
Warnings	6
Choosing the Mounting Location	6
Understanding Apparent and Dynamic True Wind	9
Adding External Sensors	9
WeatherStation Connections	10
Part and Cable Information	10
Mounts	10
Tools & Materials	11
Installing	12
Permanent Mounting	13
Attaching the Cable to the WeatherStation Instrument	14
Cable Routing and Connecting	15
Connecting to a Data Converter, Combiner, or Splitter	15
Connecting to NMEA 0183 Displays	15
Connector on Display End for OEM Cables	15
Preparing the Wires	16
Connecting	16
Connecting to an NMEA 2000® Network	17
Replacing Existing WeatherStation Installations	18
Calibrating the Compass	19
How to Calibrate	19
Pretest	19
Compass Calibration Procedure	19
Maintenance Cautions	20
Software	20
Data Management	20
Troubleshooting	21
Technical Information	22
Interfaces	22
Protocols	22
Index	23

IMPORTANT

Please read the Owner's Guide & Installation Instructions completely before installing and operating device.

Introduction

Thank you for purchasing Airmar's ultrasonic WeatherStation® Instrument. This exciting product has multiple sensors in a single unit—with no moving parts. The compact waterproof housing has a single removable cable, yet offers a broad range of functions and features.

Features

- Waterproof housing and cable system
- Fast response time and update rate
- Stable and accurate Dynamic True Wind and heading data in variable conditions
- CAN communication protocols – NMEA 2000, J1939 and ISOBUS
- Wireless connectivity via Bluetooth to Airmar's CAST™ app for viewing instrument data, system configurations and firmware updates
- Automatic baud rate detection on J1939 and ISOBUS (250kbps/500kbps)
- Improved power efficiency control via sensor configurations
- Data Logging to SmartFlex™ module
- GNSS (Global Navigation Satellite System) Constellations:
 - GPS
 - GALILEO
 - GLONASS
 - BEIDOU
 - QZSS
- SBAS (Satellite Based Augmentation System) systems:
 - WAAS
 - EGNOS
 - MSAS
 - GAGAN

WARNING

Navigation Aid Only—The WeatherStation Instrument is an aid to navigation only and should never be solely relied upon. It is not a replacement for traditional navigation aids and techniques. Only official government charts contain all the information needed for safe navigation.

Model Description

Functions & Outputs	MODEL NUMBER	
	300WX w/ Humidity	300WX
Apparent wind speed & angle	☑	☑
Dynamic (active) wind speed and direction ^a	☑	☑
Barometric pressure	☑	☑
Air temperature	☑	☑
GNSS-Enabled (Position, COG, SOG, time stamping)	☑	☑
Three-axis accelerometer for pitch & roll	☑	☑
Three-axis solid-state compass with dynamic stabilization	☑	☑
Relative humidity Calculated Dew Point Calculated Heat Index	☑	
Weatherproof rating	IP64	IP67
Automatic Baud Rate Detection (250kbps/500kbps) (J1939 and ISOBUS only)	☑	☑
Data Interface Outputs: Serial Protocols: RS232 or RS422, NMEA 0183 format Serial Data Transmission Code: ASCII CAN Protocols: NMEA 2000®, ISOBUS, J1939	☑	☑
Operating voltage	9-40 VDC	
Three-axis rate gyro for Rate of Turn	☑	☑
Heading relative to North (True or Magnetic)	☑	☑
Angle of pitch and roll	☑	☑

a. Dynamic wind speed and direction calculates vessel/vehicle speed and direction to determine actual wind speed and direction, if applicable.

Product and Configuration Specifications

Product specifications contain product information, including General Specifications, NMEA 0183 Sentences, NMEA 2000 PGNs, testing information, and more. Configuration Specifications contain Sensor Settings, PGN Settings, Sensor Intervals, Sensor Priority, and default sentences.

Contact your local sales representative to obtain copies of Product and Configuration Specifications for your WeatherStation Instrument model. Also refer to **“Part and Cable Information” on page 10.**

Warnings

Follow the safety warnings below to reduce the risk of poor product performance, property damage, personal injury, and/or death.

Installation

The WeatherStation Instrument must be installed and operated according to the instructions in this guide.

Installation Safety

Always wear PPE (personal protective equipment) as needed when installing.

Do Not Install Near Artificial Magnetic Fields

The WeatherStation Instrument must be a minimum of 1m (3') from ferrous metals and any magnetic fields to prevent interference to the magnetic compass.

Compass-safe Distance

The WeatherStation Instrument must be a minimum of 0.3m (1') from other standard and steering compasses.

Electrical Safety

The power supply must be OFF before making electrical connections.

Fuse or Circuit Breaker

Installations require a 0.5 amp fast-blow fuse or circuit breaker.

Battery

Make connections to a power source isolated from the engine start battery(s). Voltage fluctuations may cause the WeatherStation instrument to lose information and/or change operating mode.

Calibrating the Compass

The internal compass may need to be calibrated after the WeatherStation Instrument is installed. Perform the **“Replacing Existing WeatherStation Installations”** on page 18 to determine if calibration is necessary.

Replacing Existing Airmar WeatherStation Instrument Models

Some legacy cabling may not be compatible with features of the 300 Series. Refer to **“Replacing Existing WeatherStation Installations”** on page 18 when replacing existing WeatherStation installations.

Choosing the Mounting Location

For accurate readings and a reliable position signal, selecting the best location for the WeatherStation Instrument is very important. Easy access and appearance are secondary considerations. Since each installation is unique, the best separation distances vary depending on the surroundings and the particular equipment and how it is configured. Choose a location that balances the following requirements:

All Installations

- *The WeatherStation Instrument must be mounted in “clear air”, away from obstructions in any direction that will interfere with air flowing through the unit.* If there is an obstruction, mount the WeatherStation Instrument at least 2m (6') away. On land, avoid obstructions such as roofs, chimneys, trees, etc.
- If possible, mount the WeatherStation Instrument higher than any other object. Mount it a minimum of 500mm (20") above the surrounding surfaces.

Note: The higher the WeatherStation Instrument is mounted, the less accurate are the pitch and roll readings.

- To prevent interference to the internal magnetic compass:
 - Mount a minimum of 0.3 m (1') from other standard and steering compasses.
 - Mount a minimum of 1 m (3') from any structures or equipment that contains ferrous metals.
 - Mount a minimum of 1 m (3') from anything that may create a magnetic field such as magnetized materials, electric motors, electronic equipment, engines, generators, power/ignition cables, and batteries. For distances, follow the respective manufacturer's recommendations.
- To prevent interference to the internal GNSS module, see **Figure 1**.
 - It must have a clear view of the sky to receive satellite signals. A 120° view of the sky is optimal. Check for any obstructions such as other boats or buildings.
 - Mount it as far as possible from high-powered transmitting antennas to avoid mutual interference.
 - Mount it lower than any INMARSAT communications antenna.
 - Mount above or below any radar beam. Do not mount within a radar beam.

Marine Installations

Review **Figure 1** for general Marine installations. Review **Figure 2** for additional mounting information for boats and vehicles.

Figure 1: Recommended WeatherStation Locations - Marine/Office/Stationary

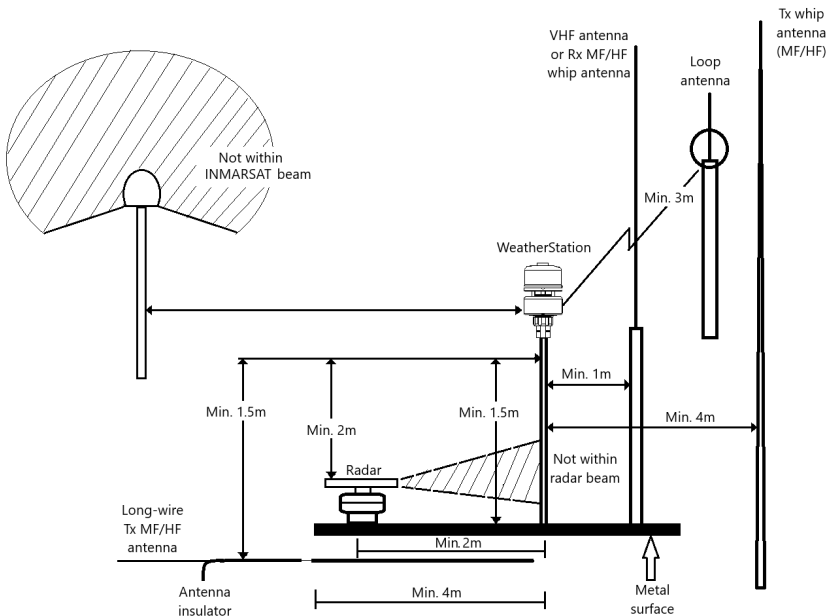

Marine/Mobile Installations

Mount the WeatherStation in clear air. Mounting the WeatherStation too low, or near a windshield, for example, can result in inaccurate wind and SOG/COG readings.

Figure 2: Boat/Vehicle mounting location in clear air (boat shown)

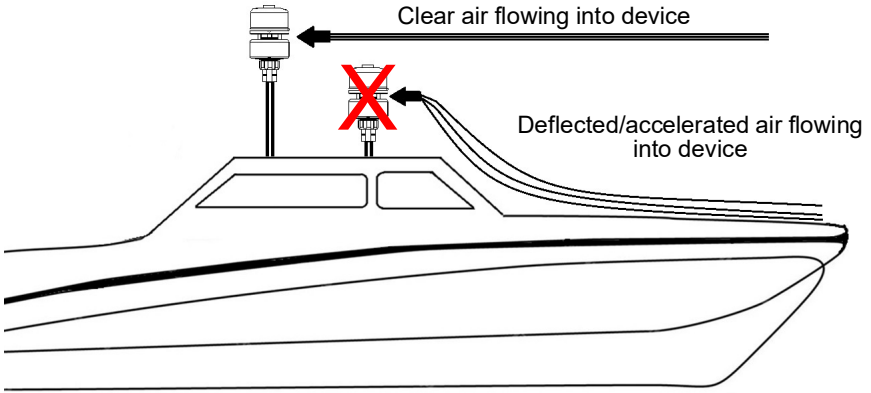

Mobile/Agricultural Installations

Review **Figure 3** for general Mobile/Agricultural installations.

- To prevent incorrect readings for mobile applications, see **Figure 3**.
- Mount WeatherStation in clear air, away from exhaust ports and engine heat, and over spray from equipment.
- Mount it high enough to ensure there is a minimum of a 120° view of the sky.

Figure 3: Recommended WeatherStation Locations - Mobile/Agricultural

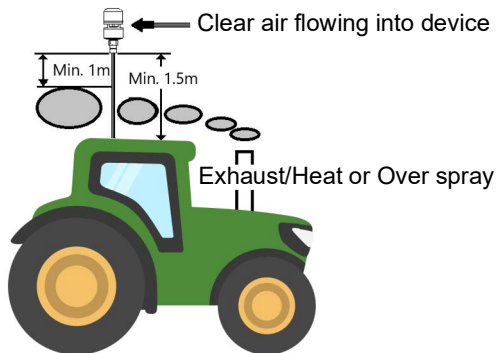

Understanding Apparent and Dynamic True Wind

The Airmar WeatherStation measures Apparent Wind Speed and Angle and calculates both Dynamic True Wind Speed (DTWS) and Wind Direction (WD). The wind readings are the same if the unit is mounted in a fixed location with the FORE (alignment notch) facing North. When stationary, WD is calculated using compass heading. However, if the unit is located on a moving vehicle/boat, the built-in navigation and/or compass calculates DTWS and WD.¹ This method uses Apparent Wind Speed and Angle, and GNSS Course Over Ground and Speed Over Ground values to compensate for the vessel speed and direction.

Refer to <https://youtu.be/u-3SMKyY4kw> for a video overview of Dynamic True Wind.

Adding External Sensors

Heading

The WeatherStation Instrument can receive data from external sensors. If provided, this data is used in the Dynamic True Wind Direction calculations. The following NMEA 0183 sentences provide heading data:

- \$GPVTG/\$GNVTG/\$GLVTG—Course Over Ground (COG) and Speed Over Ground (SOG) calculations for GPS, GNSS and GLONASS, respectively.
- \$HCHDT/\$HCHDG—Headings are used for wind calculations.

When these are seen as input from an external sensor, the output of these sentences from the WeatherStation Instrument is paused.

Water Speed

Water-speed values can be transmitted to the WeatherStation Instrument. This modifies the DTWS calculation to provide wind speed relative to water.

- NMEA 0183—VHW is used for wind speed relative to water calculation.
- NMEA 2000—PGN 128259 (water speed) is used for wind speed relative to water calculations.

The WeatherStation Instrument automatically detects whether a sensor(s) is internal, external, or not available.

- NMEA 0183—Connect the external sensor(s) to a Combiner or other NMEA 0183 repeater hardware.
- NMEA 2000—Connect the external sensor(s) to the NMEA 2000 network.

Note: *When an external speed sensor is connected to both an NMEA 0183 device and an NMEA 2000 network, the WeatherStation Instrument uses NMEA 2000 data.*

Speed-through-water

An external speed sensor can be installed, such as an Airmar Smart™ Sensor. Airmar recommends installing the DST800 to receive water depth, boat speed, and water temperature data. This data can be displayed in an MFD (Multi Function Display) or within the CAST™ Application.

1. DTWD is calculated with heading when vehicle speed is <2kts and COG when >2kts

WeatherStation Connections

The WeatherStation Instrument can be connected to a device and/or network using a cable or through the CAST Application on a Bluetooth-enabled smart device. Go to <https://www.airmar.com/quick-start-guides> for additional CAST information.

Part and Cable Information

Consult with your MFD instrument manufacturer and marine dealer to determine the correct cable Type and Length, and equipment, based on individual installation requirements. **You must have the correct cable(s) and any needed converting/connecting hardware before beginning the installation.**

For parts, contact your Distributor for local dealer information or visit <https://www.airmar.com/How-To-Buy>.

Gemeco

USA

Tel: +1-803-693-0777
email: sales@gemeco.com
web: www.gemeco.com

Airmar EMEA

Europe, Middle East, Africa

Tel: +33.(0)2.23.52.06.48
email: sales@airmar-emea.com
web: www.airmar-emea.com

Airmar ANZ

Australia, New Zealand

Tel: +61 3 8796 8888
email: sales@airmar-anz.com
web: www.airmar-anz.com

Mounts

The Airmar WeatherStation Instrument Mount kit, P/N ACC-VM10-01, is available for Stationary or Moving platforms. The WeatherStation nut is available in 1"-14 TPI UNS threads.

Figure 4: WeatherStation Instrument Mount

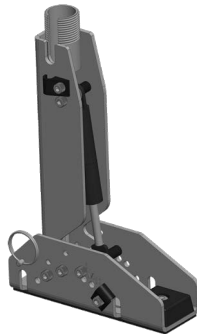

Additional mounts purchased commercially must meet the following specifications:

- Non-ferrous antenna mount with standard marine 1" -14 threads and cable pass-through
- Hardware to install antenna mount
- Extension tubes for proper installation height

Figure 5: Antenna mounts (available commercially)

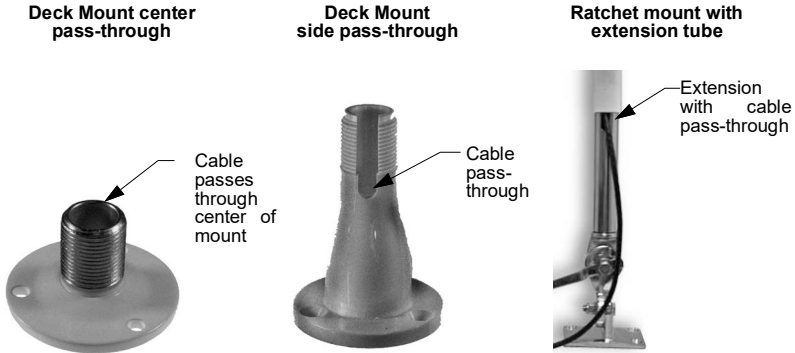

Tools & Materials

Required
PPE (Safety glasses, Dust mask, Ear protection)
Pencil
Level/Plumb
Electric drill
Drill bits
Screwdrivers

Optional/Some installations
Teflon pipe-thread tape
High quality deck gland
Grommets
Cutting pliers
Wire strippers
Heat-shrink tubing
Heat gun
Multimeter
Cable ties

Installing

Review *Caution* information **prior to installing the unit.**

- The reflector plate and the waterproof film in the WeatherStation Instrument wind channel are essential to its operation. Be careful not to scratch the plate, puncture the film, or damage in any way.
- The WeatherStation Instrument must be installed level and plumb. If the WeatherStation Instrument is tilted from the horizontal plane, it may introduce errors in the wind readings.
- To accurately measure the wind direction and heading, the alignment notch on the WeatherStation Instrument must be pointed correctly. See **Attaching the Cable to the WeatherStation Instrument.**
- Tighten and align the WeatherStation Instrument by grasping the lower housing below the reflector plate. **Hand tighten only.**
- If using a thread lock, use Teflon pipe-thread tape. Do not use a liquid thread lock as it may weaken the plastic, causing it to swell and crack.

Figure 6: WeatherStation Instrument

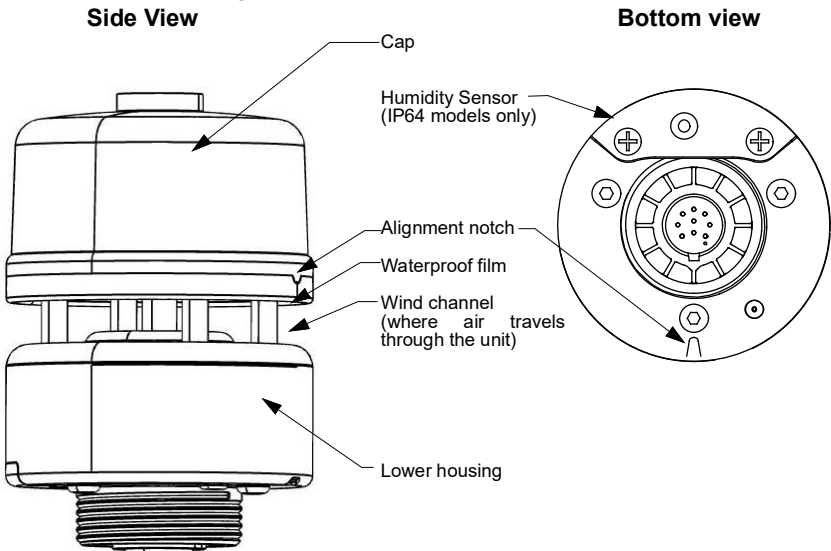

Permanent Mounting

1. Place the mounting hardware at the selected location. Orient any cable exit in the direction that you want the cable to travel, **Figure 7**.
2. Position the mounting hardware at a 90° angle to the mounting surface. If necessary, use shims to make the mounting surface level.
3. Mark the holes for the mounting screws.
4. Drill the holes for the mounting screws and the cable exit, if necessary. If the cable is to be fed through a deck, install a high quality deck gland.
5. Using purchased screws, fasten the mount in place.
6. Screw an extension tube onto the antenna mount, if desired.

Important: Only use aluminum or high-grade stainless steel extension tubes, as ferrous objects can interfere with the compass heading.

Figure 7: Side View

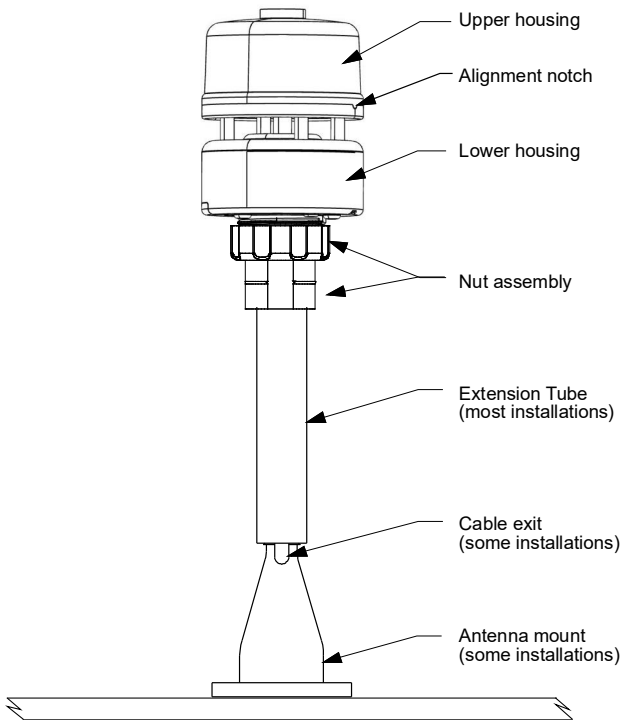

Attaching the Cable to the WeatherStation Instrument

1. With the nut assembly on the cable near the WeatherStation connector, thread the cable through the extension tube (if used), antenna mount, and the cable exit. *Leave ~2 inches (5 cm) of cable extending beyond the nut assembly. See **Figure 8**.*
2. Remove the protective cover from the connector.
3. Plug the connector into the WeatherStation Instrument, aligning the alignment key into a notch in the base of the WeatherStation Instrument.
4. Screw the nut assembly onto the top of the antenna mount /extension tube. **Hand tighten** only. Do not over-tighten.

Note: *If using a thread lock, use Teflon pipe thread tape only.*

5. Slide the captive nut upward and screw it onto the lower housing of the WeatherStation Instrument, **Figure 8. Hand tighten only.**

Caution: *Do not over-tighten or twist the cable.*

6. When tightening, set the Alignment Notch, **Figure 8**, according to the following instructions:

- **Moving vehicle / boat** - The alignment notch must point forward and be parallel to the centerline of the vehicle / boat.
- **Stationary install** - Align the notch to North using a Compass if Wind Direction relative to magnetic North is desired. If Wind Direction relative to True North is desired, add/subtract the Magnetic Variation (declination) for the installation position/area.

Figure 8: Attaching the cable to the WeatherStation Instrument

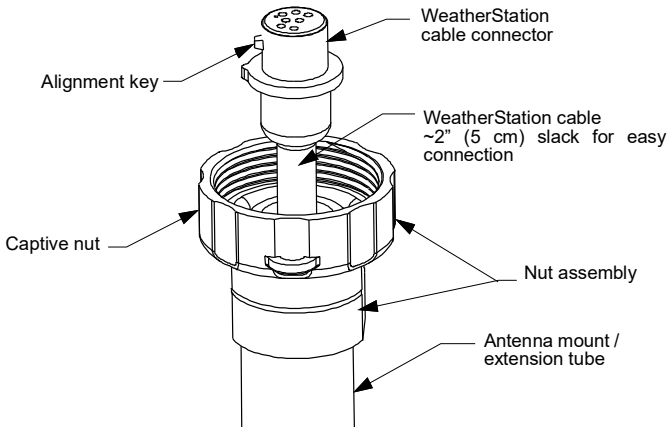

Cable Routing and Connecting

Depending on the equipment you will be using, route the WeatherStation cable to a Converter, Combiner, Splitter, an NMEA 0183 display, or an NMEA 2000 network. After reading the cautions below, go to the appropriate instructions.

- Do not remove the waterproof connector(s) to ease cable routing. Instead, buy a cable without a connector. Instructions for wiring are supplied with supplemental cables.
- To prevent stress and damage to cable, avoid tight bends. Use a bend radius calculator if required.
- To reduce electrical interference from other electrical wiring and any on-board equipment with strong magnetic fields such as radar equipment, radio transmitters, engines, generators, etc., separate cables by at least 1 m (3'). Ensure that all cable shields are grounded to an Earth ground.
- Be careful not to tear cable jackets when passing them through compartments, bulkheads, or walls. Use grommets to prevent chaffing.
- Use a multimeter to check polarity and connections to the power supply before applying power to the WeatherStation Instrument.
- Verify WeatherStation functionality BEFORE securing cable.
- Coil any excess cable length and secure it with cable ties to prevent damage.

Connecting to a Data Converter, Combiner, or Splitter

Important: To connect to a PC it is necessary to install a Data Converter or Combiner. Follow the installation instructions that are supplied with the unit.

Connecting to NMEA 0183 Displays

Cable Routing

1. Route the WeatherStation cable to the display.

Note: *Do not fasten the cable in place until after testing unit functionality.*

2. Attach cable to display.

Connector on Display End for OEM Cables

1. If the WeatherStation cable has a connector on the display end, and it can be plugged into the port on the NMEA 0183 display, do so now.
2. Coil any excess cable and secure it with cable ties to prevent damage. Fasten the cable in place.

Caution: The WeatherStation Instrument is either a RS422 or RS232 protocol. Follow the wiring diagram that matches the WeatherStation Instrument. If it is wired for the wrong standard, it will not transmit and receive data properly.

Preparing the Wires

If the display does not have NMEA 0183 output connections, the yellow and orange wires are not needed. Apply heat-shrink tubing to each unused wire. Alternatively, the yellow and orange wires can be connected to an external sensor.

1. Allowing an extra 25 cm (10") for wiring ease, cut the cable to length.
2. Strip 60mm (2-1/2") of the outer jacket and foil shielding from the cut end of the cable, **Figure 9**.
3. Strip 10 mm (3/8") of conductor insulation from the end of each colored wire.
4. Protect the cable's foil shielding from causing a short by using heat-shrink tubing around the jacket where the wires emerge from the cable. The tubing must overlap the wires a minimum of 6 mm (1/4"). Shrink the tubing using a heat gun.
5. Being sure the power supply is OFF, connect the wires to the display.
6. Fasten the cable in place.
7. The installation is complete. To begin receiving data, refer to the owner's manual that came with the display device.

Connecting

Refer to the appropriate wiring diagram and the owner's manual that came with the display to connect the colored wires.

Figure 9: NMEA 0183 WeatherStation Cable

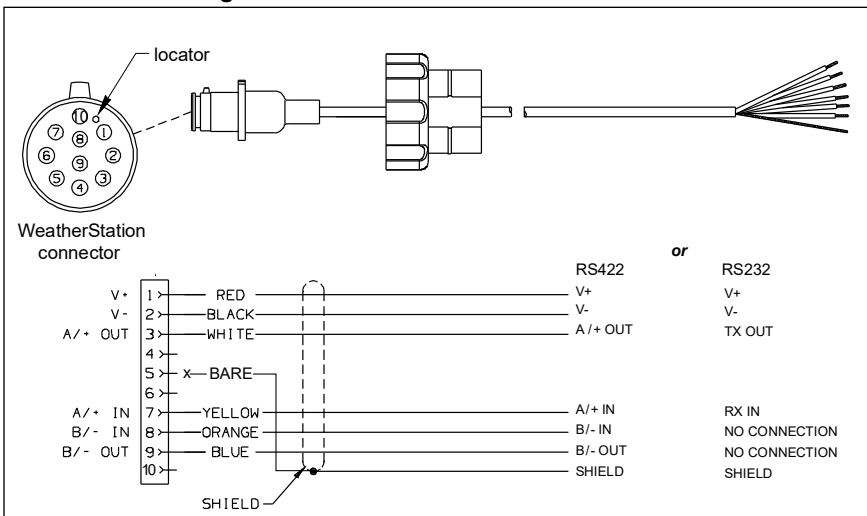

Connecting to an NMEA 2000® Network

Caution: Only two termination resistors are required on an NMEA 2000 network. More than two degrades the bus performance.

1. Route the WeatherStation cable to the NMEA 2000 network.
2. Plug the NMEA 2000 connector into the network node, **Figure 10**.
3. Coil any excess cable and secure with cable ties to prevent damage.

Figure 10: NMEA 2000 Weather Station Cable [6m (20') shown]

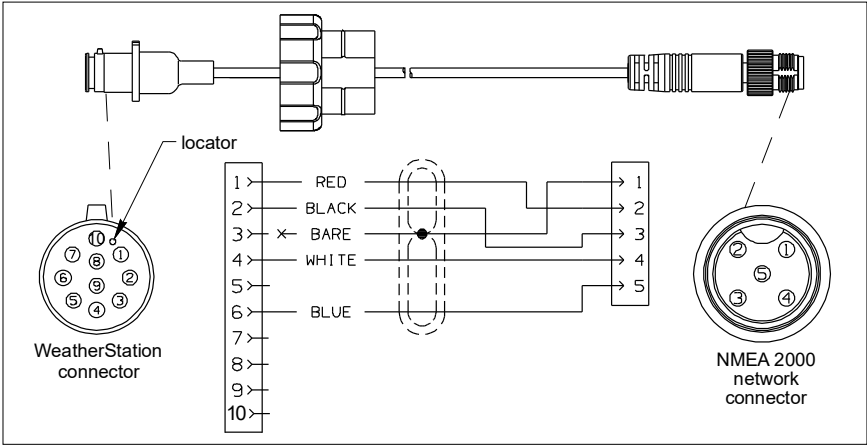

Note: WeatherStation cables greater than 6m (20') have a termination resistor built into the WeatherStation connector, **Figure 11**.

Caution: If the cable has a termination resistor, verify it is at the end of NMEA 2000 bus, otherwise data may not be transmitted correctly.

Figure 11: NMEA 2000 WeatherStation Cable [10m (33') shown]

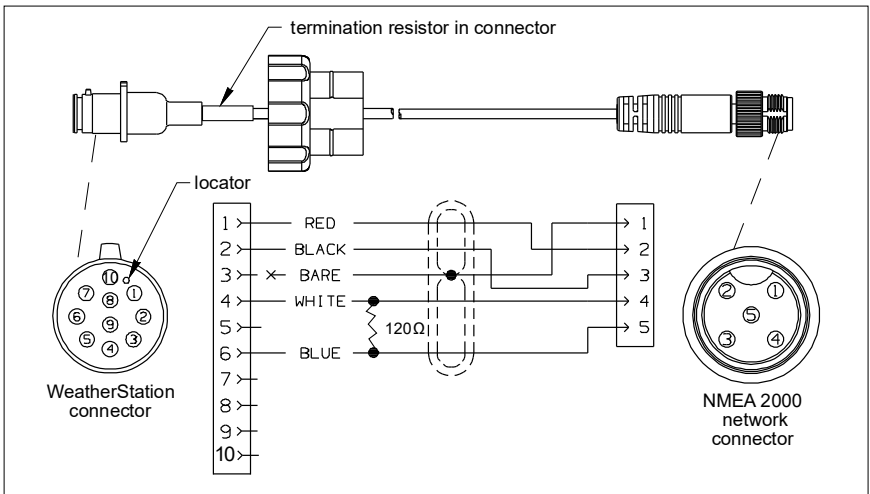

Replacing Existing WeatherStation Installations

The 300WX Series is compatible with most prior WeatherStation installations. Use the following guidelines to check if your existing installation is compatible with the 300WX series, or contact your equipment dealer for guidance.

- Cable - If the existing cable contains the same wires and connector, it is compatible with the 300WX.
- 200WX - The NMEA 0183 sentences and NMEA 2000 PGNs are the same as the existing 200WX.

Serial Command Requirements

Serial Commands for the 300WX series require an 8 bit XOR checksum at the sentence end. Consult with your marine dealer or installer for information on editing Sentences to add the correct checksum value.

Calibrating the Compass

WARNING: For maximum accuracy, the compass may require calibration after installation. Perform the **Pretest** to determine if calibration is necessary.

How to Calibrate

Calibration can be done several ways:

- **Wireless**—Use the Airmar CAST app **Compass Calibration** command. Refer to the CAST Quick Start Guide and CAST User Guide for additional information. See <https://www.airmar.com/quick-start-guides> for information on downloading and installing the CAST app.
- **Auto Mode**—Follow the **Pretest** and **Compass Calibration Procedure** next.

Pretest

Go to an appropriate testing location:

- **Vehicle/Tractor**—Drive to an open parking lot or field, away from other vehicles and ferrous objects.
 - **Boat**—In calm seas, navigate to an open area of water, 0.8 km (0.5 mile) of open space away from other boats and ferrous objects.
1. Pick a heading and proceed in this direction for approximately 0.8 km (0.5 mi).
 2. Check the values of another compass and compare the WeatherStation heading data to the compass.
 3. Turn 180° and proceed back to the original position.
 4. Re-check the values. If the data agrees, there is no magnetic influence to the WeatherStation Instrument. The compass does NOT need to be calibrated.
 5. If the data does not agree, continue with **Compass Calibration Procedure**.

Compass Calibration Procedure

Important: Calibration requires the vehicle/boat to complete 2 to 3 large circles. In the event of a calibration failure, repeat the procedure.

Caution: Boat—The Pretest and Compass Calibration Procedure must be done in calm seas in a 0.8 km (0.5 mile) open area away from other boats and ferrous objects such as structures and aids to navigation. Avoid congested areas and waters with strong currents as calibration will be difficult and possibly hazardous.

1. At the site where the pretest was performed, select the display page on the NMEA Instrument that shows **Heading**.
2. Shut OFF and then turn ON the DC power that is connected to the WeatherStation Instrument.

3. Within 2 minutes of cycling power to the WeatherStation Instrument, start the vehicle/boat in a slow [4.5 to 7 MPH (4 to 6 knots)] circular turn that takes about 2 to 3 minutes to complete.*

* The optimal turn rate is 180° / minute

4. If the vehicle/boat completes 1.5 circles within 3 to 4.5 minutes, Auto-Calibration begins. Heading stops being reported on any NMEA 0183 or NMEA 2000 display until the calibration is finished.
5. Keep turning in the same circle for 1 to 2 more complete circles. *Do not change the speed or rate of turn through the circle.*
6. When calibration is successful, Heading returns to the display. If calibration fails, the display flashes Heading ON and OFF in 10 second intervals for 60 seconds. (Display times vary by manufacturer.) If calibration fails, repeat the calibration. If repeated attempts fail, contact Technical Support.

Maintenance Cautions

- Do not disassemble the WeatherStation Instrument. Removing the three main screws holding the lower housing will damage the waterproof seal, voiding the warranty.
- Do not immerse in water or pressure wash. Doing so may allow water to infiltrate the WeatherStation Instrument, voiding the warranty.
- The reflector plate and the waterproof film found in the wind channel of the WeatherStation Instrument are essential to its operation. The waterproof film protects the transducers, so be careful to keep it intact. Do not scratch the reflector plate or damage it in any way.
- Keep the wind channel free of spider webs, insects, dirt, and other debris.

Cleaning

Since the WeatherStation Instrument has no moving parts, it requires minimal maintenance. Clean the exterior with a damp cloth and mild household detergent. Gently thread an alcohol wipe through the wind channel to clean.

Note: Do not allow the wipe to contact the blue film.

Software

Revisions

Airmar may release updated versions of the WeatherStation firmware and the CAST™ app. Periodically check Airmar's website at <https://www.airmar.com> and the respective Application site for updates. Use the CAST™ app to upgrade the WeatherStation™ Firmware.

WeatherCaster™ Software

The WeatherCaster™ Software is not compatible with the 300WX Series.

Data Management

The CAST™ app can assist with data management.

- **Data Management**—Refer to the CAST User Guide to enable/disable Data Sentences and PGNs and to change the frequency of sensor output to optimize network bandwidth.

Troubleshooting

No Readings or Inaccurate Readings

- Is Bluetooth enabled on the smart device?
- Is there power to the WeatherStation Instrument?
- Are all connections secure?
- Is the cable free of kinks or damage?
- Is the wiring correct?
- Are there any obstructions in the wind channel?
- Are the temperature and humidity sensors clean?
- Is there ice on the WeatherStation Instrument?

No GNSS Fix

- Does the WeatherStation Instrument have a clear view of the sky?

Wind Readings Are Too Low/Too High on Moving Platform

- Is the WeatherStation Instrument mounted forward and low on the boat/vehicle's hardtop in dead air?

*Move the WeatherStation Instrument farther back and higher. Refer to **Marine/Mobile Installations**.*

Technical Information

NMEA 2000: Load Equivalency Number

LEN is the amount of current a device draws from an NMEA 2000 network.
(1 LEN = 50 mA)

NMEA 2000 Load Equivalency Number (LEN)

300WX..... 2

Interfaces

Interface	Supported Protocols	Additional details
CANbus	NMEA 2000, J1939, ISOBUS	The factory default is NMEA 2000 ^a
RS422/RS232	NMEA 0183	Product option RS422 or RS232
Bluetooth	SDS (proprietary)	For use with CAST App

a. J1939 and ISOBUS are selectable with CAST only.

Protocols

Protocol Name	Version/Date	Description
NMEA 2000	V3.000	Supports multiple standard and proprietary PGNs
NMEA 0183	V4.11	Supports multiple standard and proprietary sentences
ISOBUS	ISO 11783 issued 2021	Agricultural and forestry applications, including tractors, sprayers, and other equipment; derived from J1939 protocols
J1939	SAE J1939 issued 2021	Standards that define how ECUs communicate via the CANbus in heavy-duty vehicles.

Specifications

Product specifications are measured under laboratory conditions. The installation and surrounding environment can impact the product's performance.

Abbreviations and Acronyms

CANController Area Network
ECUElectronic Control Unit
EGNOSEuropean Geostationary Navigation Overlay Service
GNSSGlobal Navigation Satellite System
MFDMulti Function Display
NPTNational Pipe Thread
NMEANational Marine Electronics Association
SBASSatellite Based Augmentation System
WAASWide Area Augmentation System

Glossary

FirmwareThe software within the WeatherStation hardware
CAST™ AppThe Smart Device application program

Trademarks

Airmar® is a registered trademark of Airmar Technology Corporation.
CAST™ is a trademark of Airmar Technology Corporation.
NMEA 2000® is a registered trademark of the National Marine Electronics Assoc.
Smart™ Sensor is a trademark of Airmar Technology Corporation.
WeatherStation® Instrument is a trademark of Airmar Technology Corporation.

Index

A
Abbreviations and Acronyms 22
Adding External Sensors 9
Attaching the Cable to the WeatherStation Instrument 14
C
Cable Routing and Connecting 15
Calibrating the Compass 19
Choosing the Mounting Location 6
Compass Calibration Procedure 19
Connecting 16
Connecting to a Data Converter, Combiner, or Splitter 15
Connecting to NMEA 0183 Displays 15
Connector on Display End for OEM Cables 15
D
Data Management 20
F
Features 4
H
How to Calibrate 19
I
Installing 12
Interfaces 22
Introduction 4
M
Maintenance Cautions 20
Model Description 5
Mounts 10
O
Owner's Guide & Installation Instructions 1
P
Part and Cable Information 10
Permanent Mounting 13
Preparing the Wires 16
Pretest 19
Product and Configuration Specifications 5
Protocols 22
R
Replacing Existing WeatherStation Installations 18
S
Serial Command Requirements 18
Software 20
Specifications 22
T
Table of Contents 3
Technical Information 22
Tools & Materials 11
Troubleshooting 21
U
Understanding Apparent and Dynamic True Wind 9
W
Warnings 6
WeatherStation Connections 10



35 Meadowbrook Drive, Milford, New Hampshire 03055-4613, USA
www.airmar.com

